



SHAEC25023685308

2025 09 15

1 7

1

MOS

SGS

SHP25-031070

2025 09 09

2025 09 09 ~ 2025 09 15

RoHS	2011/65/EU	II	(EU) 2015/863-
(DEHP)	(PBB)	(PBDE)	(2-)
(DIBP)	(BBP)	(DBP)	



Carol Luo

Scan to see the report





... " / SHAEC25023685308 fi fl / 2025 09 15 2 7

... # \$ /

		SGS ID	
SN1	A2	SHA25-0236853-0001.C002	

(1) 1 mg/kg = 1 ppm = 0.0001%

(2) MDL=

(3) ND = (< MDL)

(4) "-" =



SHAEC25023685308

fi fl / 2025 09 15

3 7

			MDL	A2
(NonaBDE)	-	mg/kg	25	ND
(DecaBDE)	-	mg/kg	25	ND
(2-) (DEHP)	1000	mg/kg	50	ND
(BBP)	1000	mg/kg	50	ND
(DBP)	1000	mg/kg	50	ND
(DIBP)	1000	mg/kg	50	ND

- (1) RoHS (EU) 2015/863
- (2) IEC 62321 EN 62321
- (3) 2021 7 22 DEHP BBP DBP DIBP

ILAC-G8:09/2019

w=0



• • " •
• /

SHAEC25023685308

fi fl / 2025 09 15

4 7

0 1 ' ' 2 3 4

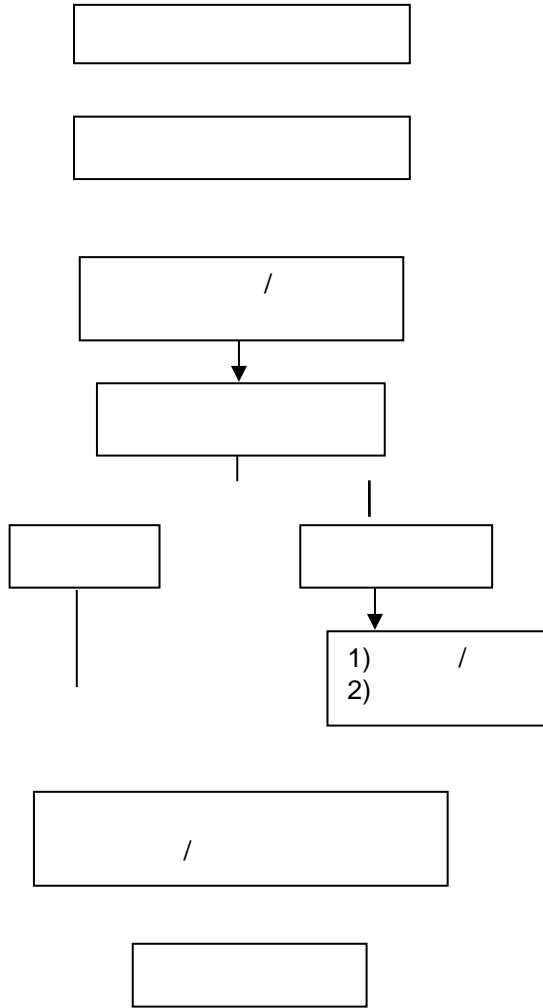



j k l 2 3 4

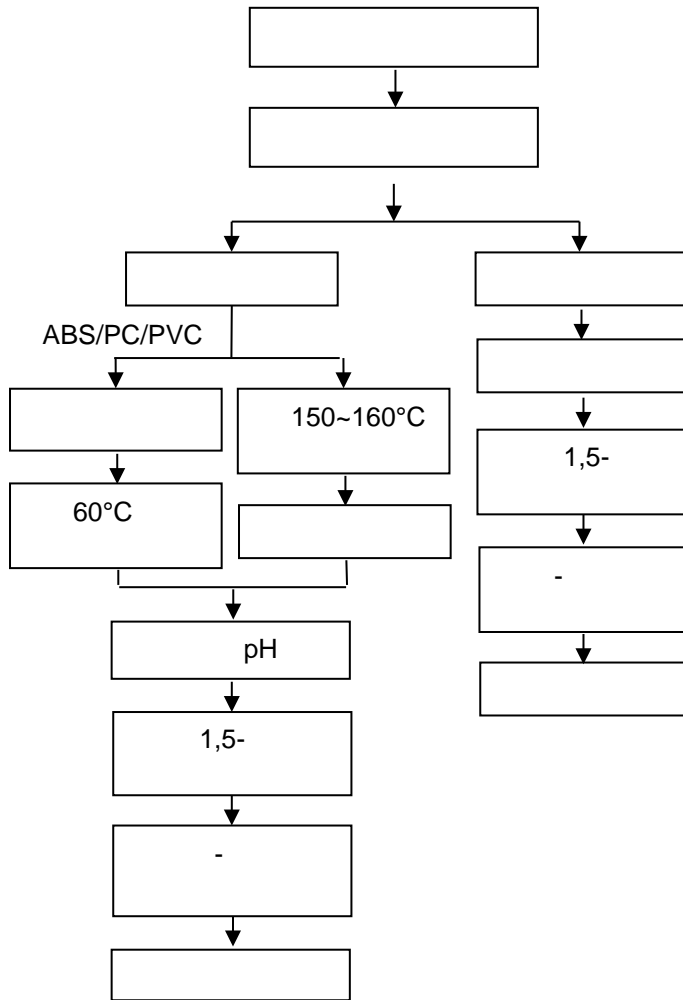



• • " ' . /

~ | / SHAEC25023685308

fi fl / 2025 09 15

6 7

• • 2 3 4

• • " • ~ 1 /