

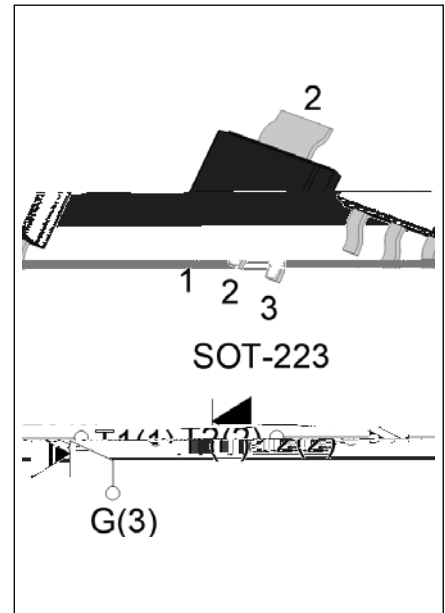

JST130V-600T 0.8A TRIAC

Rev.A.1.1

The JST130V-600T triac is suitable for general purpose AC switching. It can be used as an ON/OFF function in applications such as heating regulation, induction motor starting circuits, for phase control operation in light dimmers, motor speed controllers. Package SOT-223 is RoHS compliant.



Symbol	Value	Unit
		A
V_{DRM}/V_{RRM}	600	V
		mA

	Symbol	Value	Unit
Storage junction temperature range	T_{stg}	-40-150	
Operating junction temperature range	T_j	-40-125	
Repetitive peak off-state voltage ($T_j=25^\circ\text{C}$)	V_{DRM}	600	V
Repetitive peak reverse voltage ($T_j=25^\circ\text{C}$)	V_{RRM}	600	V
RMS on-state current ($T_c = 97^\circ\text{C}$)	$I_{T(RMS)}$	0.8	A
Non repetitive surge peak on-state current (full cycle, $t_p=16.6\text{ms}$, $T=25^\circ\text{C}$)	I_p	10	A
I^2t value for fusing ($t_p=10\text{ms}$, T_j)			s^2
Critical rate of rise of on-state current ($I_G=2 \times I_{GT}$, $f=100\text{Hz}$, $T_j=125^\circ\text{C}$)	di/dt	30	A/ μs
		20	
Peak gate current ($t = 20\mu\text{s}$, $T=125^\circ\text{C}$)	I_G	1	A
Average gate power dissipation (T_j)	$P_{G(AV)}$	0.1	W
Peak gate power	P_{GM}	5	W
Peak pulse voltage	V_{pp}	2.5	kV

(FIG.8)

(T_j=25 unless otherwise specified)

Symbol	Test Condition	Quadrant	Value		Unit
I _{GT}	V _D =12V R _L =33	ALL	MAX.	5	mA
V _{GT}		ALL	MAX.	1.3	V
V _{GD}	V _D =V _{DRM} T _j =125 R _L =3.3k	ALL	MIN.	0.2	V
I _L	I _G =1.2I _{GT}	- -	MAX.	5	mA
				15	
I _H	I _T =50mA		MAX.	5	mA
dV/dt	V _D =400V Gate Open T _j =110		MIN.	30	V/μs
(dV/dt) _c	(dI/dt) _c =0.3A/ms, T _j =110		MIN.	1	V/μs
t _{on}	I _G =10mA I _A =200mA I _R =20mA T _j =25		TYP.	2	μs
t _{off}				20	

Symbol	Parameter		Value(MAX.)	Unit
V _{TM}	I _{TM} =1A t _p =380μs	T _j =25	1.5	V
V _{TO}	Threshold voltage	T _j =125	1.01	V
R _D	Dynamic resistance	T _j =125	316	m
I _{DRM}	V _D =V _{DRM} V _R =V _{RDM}	T _j =25	5	μA
I _{RDM}		T _j =125	0.2	mA

Symbol	Parameter	Value	Unit
R _{th(j-c)}	junction to case (AC)	25	W
R _{th(j-a)}	junction to ambient (AC)	120	W

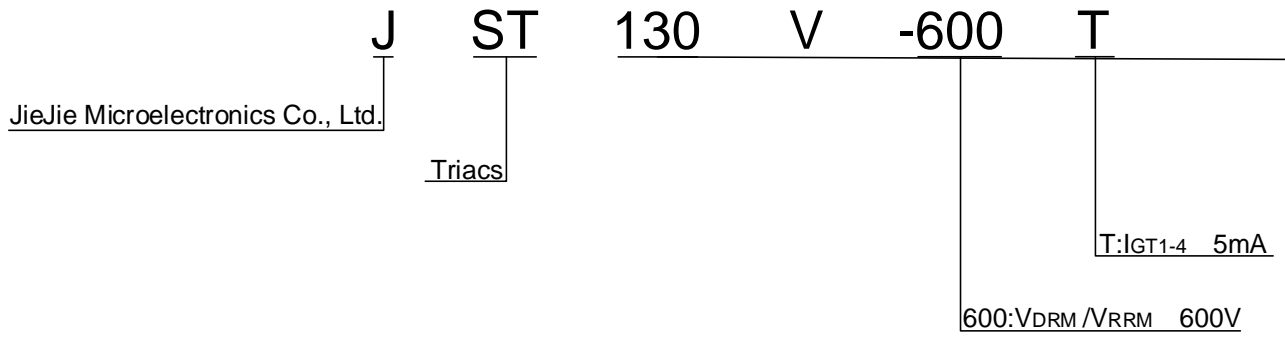

FIG.1: Maximum power dissipation versus RMS on-state current

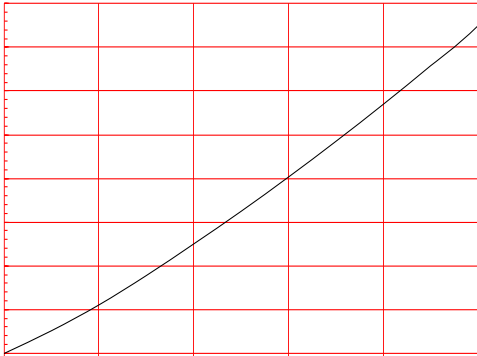
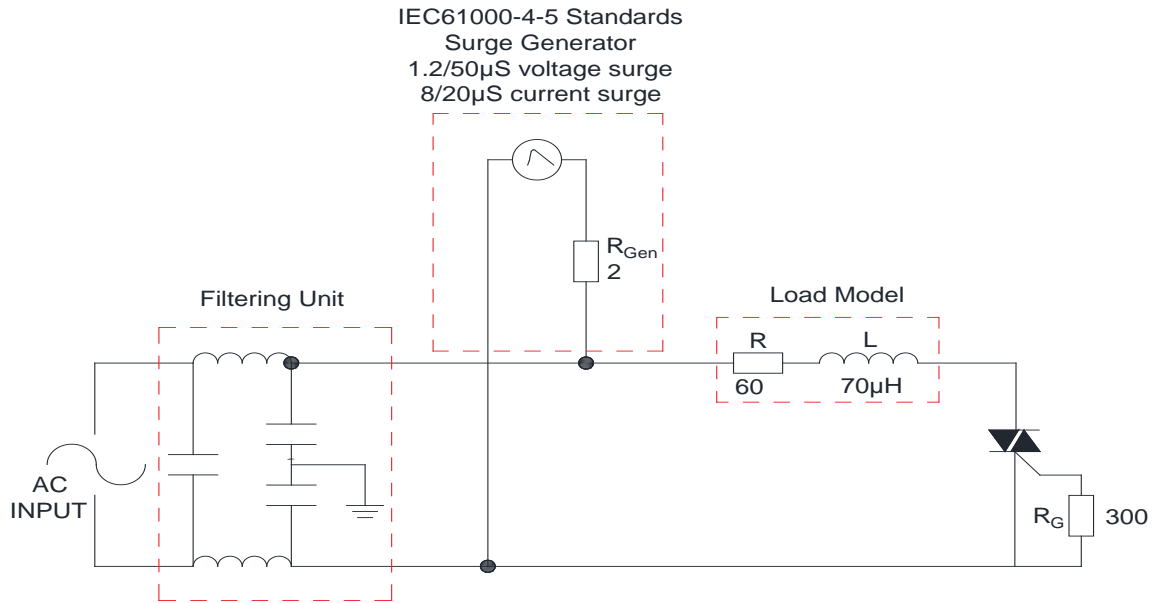

FIG.2: RMS on-state current versus case temperature

FIG.7: Relative variations of gate trigger current, holding current and latching current versus junction temperature



FIG.8 Test circuit for inductive and resistive loads to IEC-61000-4-5 standards



Order code	Voltage V_{DRM}/V_{RRM} (V)	IGT(mA)	Package	Base qty. (pcs)	Delivery mode
		- - -			
JST130V-600T	600	5	SOT-223	4,000	Tape & Reel

Document Revision History

Ref.	Dimensions					
	Millimeters			Inches		
	Min.	Typ.	Max.	Min.	Typ.	MaW85 2

-

Information furnished in this document is believed to be accurate and reliable. However, Jiangsu JieJie Microelectronics Co., Ltd. assumes no responsibility for the consequences of use without consideration for such information nor use beyond it. Information mentioned in this document is subject to change without notice, apart from that when an agreement is signed, Jiangsu JieJie complies with the agreement.

Products and information provided in this document have no infringement of patents. Jiangsu JieJie assumes no responsibility for any infringement of other rights of third parties which may result from the use of such products and information. This document supersedes and replaces all information previously supplied.

 is a registered trademark of Jiangsu JieJie Microelectronics Co., Ltd.
Copyright © 2025 Jiangsu JieJie Microelectronics Co., Ltd. All rights reserved.