



## JST12E-600BW 12A TRIAC

Rev.A.1.1

The JST12E-600BW triac is suitable for general purpose AC switching. It can be used as an ON/OFF function in applications such as heating regulation, induction motor starting circuits, for phase control operation in light dimmers, motor speed controllers. JST12E-600BW snubberless triac is especially recommended for use on inductive loads. Package TO-263 is RoHS compliant.

Parameter	Symbol	Value	Unit
Storage junction temperature range	$T_{stg}$	-40-150	
Operating junction temperature range	$T_j$	-40-125	
Repetitive peak off-state voltage ( $T_j=25^\circ\text{C}$ )	$V_{DRM}$	600	V

Peak pulse voltage ( $T_j=25$ ; non-repetitive, off-state; FIG.8)	$V_{pp}$	4.5	kV
----------------------------------------------------------------------	----------	-----	----

( $T_j=25$  unless otherwise specified)

Symbol	Test Condition	Quadrant	Value		Unit
$I_{GT}$	$V_D=12V R_L=33$	- -	MAX.	50	mA
$V_{GT}$		- -	MAX.	1	V
$V_{GD}$	$V_D=V_{DRM} T_j=125$ $R_L=3.3k$	- -	MIN.	0.2	V
$I_L$	$I_G=1.2I_{GT}$	-	MAX.	70	mA
				90	
$I_H$	$I_T=500mA$		MAX.	50	mA
dV/dt	$V_D=400V$ Gate Open $T_j=125$		MIN.	2000	V/ $\mu s$
(dI/dt)c	(dV/dt)c=20V/ $\mu s$ $T_j=125$		MIN.	20	A/ms
$t_{on}$	$I_G=80mA I_A=400mA I_R=40mA$ $T_j=25$		TYP.	5	$\mu s$
$t_{off}$				50	

Symbol	Parameter		Value(MAX.)	Unit
$V_{TM}$	$I_{TM}=17A t_p=380\mu s$	$T_j=25$	1.5	V
$V_{TO}$	Threshold voltage	$T_j=125$	0.77	V
$R_D$	Dynamic resistance	$T_j=125$	35	m
$I_{DRM}$	$V_D=V_{DRM} V_R=V_{RRM}$	$T_j=25$	5	$\mu A$
$I_{RRM}$		$T_j=125$	0.4	mA

Symbol	Parameter	Value	Unit
$R_{th(j-c)}$	junction to case (AC)	1.3	$\text{/W}$
$R_{th(j-a)}$	junction to ambient (AC, in free air, $S=2cm^2$ )	45	$\text{/W}$





**FIG.7:** Relative variations of gate trigger current, holding current and latching current versus junction temperature



Order code	Voltage V <sub>DRM</sub> /V <sub>RRM</sub> (V)	IGT(mA)	Package	Base qty. (pcs)	Delivery mode
		- -			
JST12E-600BW	600	50	TO-263	50	Tube
JST12E-600BW-TR				800	Tape& Reel

**Document Revision History**

Date	Revision	Changes
Apr.11, 2023	A.1.0	Last updated
Oct.20, 2025	A.1.1	Revise PACKAGE MECHANICAL DATA



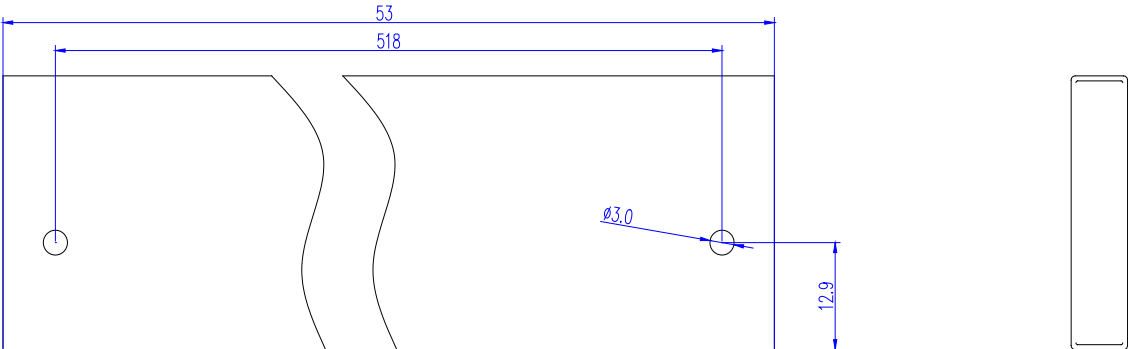

Information furnished in this document is believed to be accurate and reliable. However, Jiangsu JieJie Microelectronics Co., Ltd. assumes no responsibility for the consequences of use without consideration for such information nor use beyond it. Information mentioned in this document is subject to change without notice, apart from that when an agreement is signed, Jiangsu JieJie complies with the agreement.

Products and information provided in this document have no infringement of patents. Jiangsu JieJie assumes no responsibility for any infringement of other rights of third parties which may result from the use of such products and information. This document supersedes and replaces all information previously supplied.

 is a registered trademark of Jiangsu JieJie Microelectronics Co., Ltd.

Copyright © 2025 Jiangsu JieJie Microelectronics Co., Ltd. All rights reserved.