

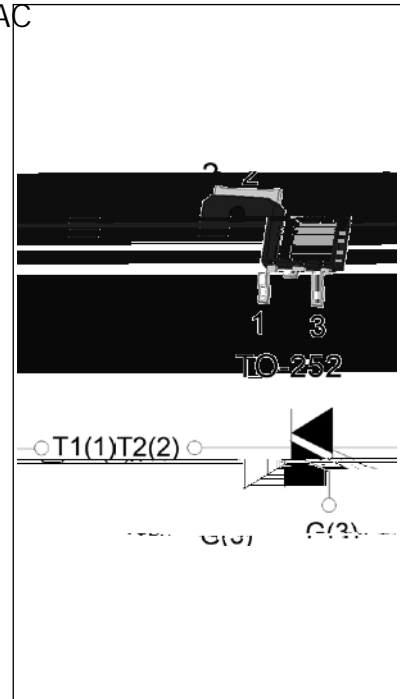

DESCRIPTION:

The JST04K-600CW triac is suitable for general purpose AC switching. It can be used as an ON/OFF function in applications such as heating regulation, induction motor starting circuits, for phase control operation in light dimmers, motor speed controller. JST04K-600CW snubberless triac is specially recommended for use on inductive loads. Package TO-252 is RoHS compliant.



MAIN FEATURES

Symbol	Value	Unit
$I_{T(RMS)}$	4	A
V_{DRM} / V_{RRM}	600	V
$I_{GT} / /$	35/35/35	mA

ABSOLUTE MAXIMUM RATINGS

Parameter	Symbol	Value	Unit
Storage junction temperature range	T_{stg}	-40-150	
Operating junction temperature range	T_j	-40-125	
Repetitive peak off-state voltage ($f=25$)	V_{DRM}	600	V
Repetitive peak reverse voltage ($f=25$)	V_{RRM}	600	V
RMS on-state current ($T=97$)	$I_{T(RMS)}$	4	A
Non repetitive surge peak on-state current (full cycle, $p=20ms$, $f=25$)	I_{TSM}	40	A
Non repetitive surge peak on-state current (full cycle, $p=16.6ms$, $f=25$)		44	
I^2t value for fusing ($t=10ms$, $T=25$)	I^2t	8	A^2s
Critical rate of rise of on-state current ($I_G=2 \times I_{GT}$, $f=100Hz$, $T=125$)	di/dt	80	A/s
Peak gate current ($t_p=20s$, $T_j=125$)	I_{GM}	4	A
Average gate power dissipation ($T=125$)	$P_{G(AV)}$	0.5	W
Peak gate power	P_{GM}	10	W

Peak pulse voltage ($T_j=25$; non-repetitive, of state; FIG.8)	V_{pp}	4	kV
---	----------	---	----

ELECTRICAL CHARACTERISTICS ($T_j=25$ unless otherwise specified)

Symbol	Test Condition	Quadrant	Value		Unit
I_{GT}	$V_D = 12V$ $R_L = 33$	- -	MAX.	35	mA
V_{GT}		- -	MAX.	1	V
V_{GD}	$V_D = V_{DRM}$ $T_j = 125$ $R_L = 3.3k$	- -	MIN.	0.2	V
I_L	$I_G = 1.2I_{GT}$	-	MAX.	50	mA

ORDERING INFORMATION

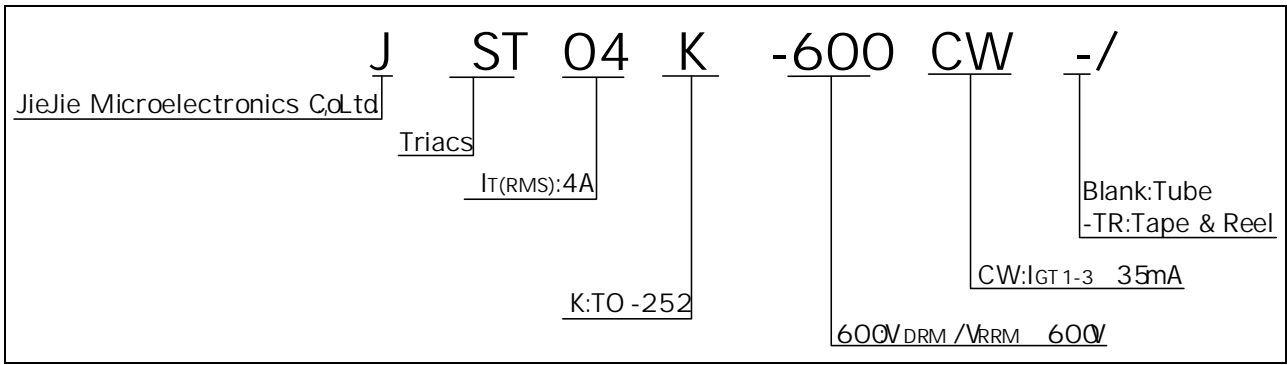

FIG.1 : Maximum power dissipation versus RMS on-state current

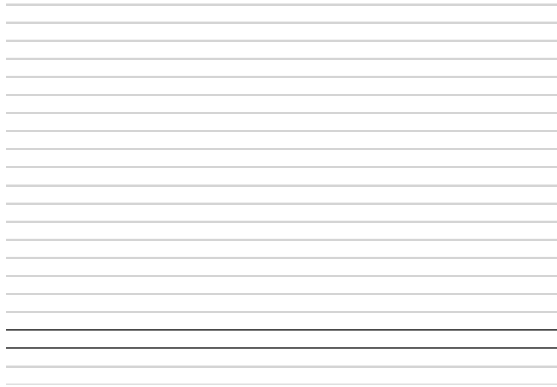

FIG.2: RMS on-state current versus case temperature

JST04K-600CW

DELIVERY MODE



