



JCT812TA 12A SCR

Rev.A.1.1

JCT812TA silicon controlled rectifier is specifically designed for medium power switching and phase control applications. High current density due to mesa technology; SIPOS and Glass Passivation technology used has reliable operation up to 125 °C junction temperature. Low I_{GT} parts available. From all three terminals to external heatsink, JCT812TA provides a rated insulation voltage of 2500 V_{RMS} , complying with UL standards (File ref: E252906). Package TO-220A is RoHS compliant.



Parameter	Symbol	Value	Unit
Storage junction temperature range	T_{stg}	-40-150 (06)	s

Peak gate current ($t_p=20\text{ s}$, $T_j=125\text{ }^\circ\text{C}$)	I_{GM}	4	A
Average gate power dissipation ($T_j=125\text{ }^\circ\text{C}$)	$P_{G(AV)}$	1	W
Peak gate power	P_{GM}	10	W
Peak pulse voltage ($T_j=25\text{ }^\circ\text{C}$; non-repetitive,off-state;FIG.7)	V_{pp}	0.5	kV

($T_j=25\text{ }^\circ\text{C}$ unless otherwise specified)

Symbol	Test Condition	Value			Unit
		MIN.	TYP.	MAX.	
I_{GT}	V_D				V

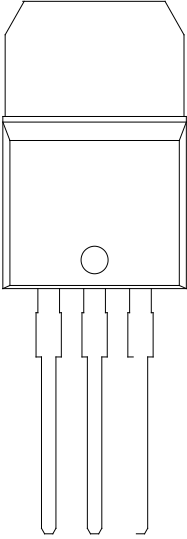
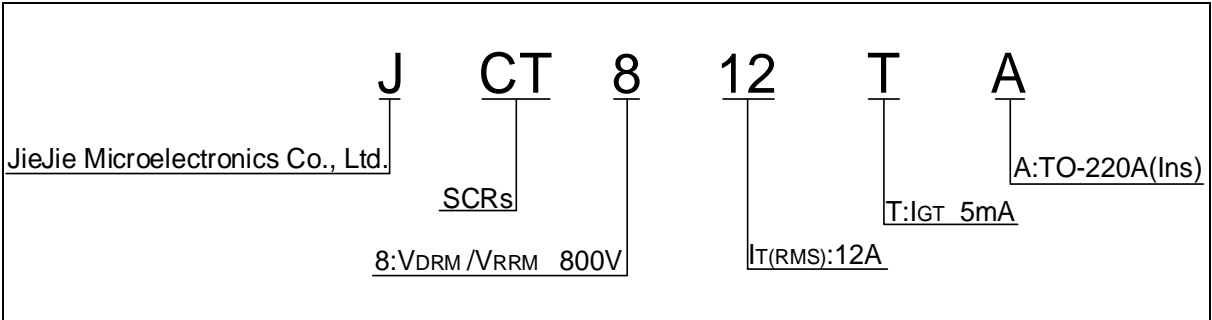
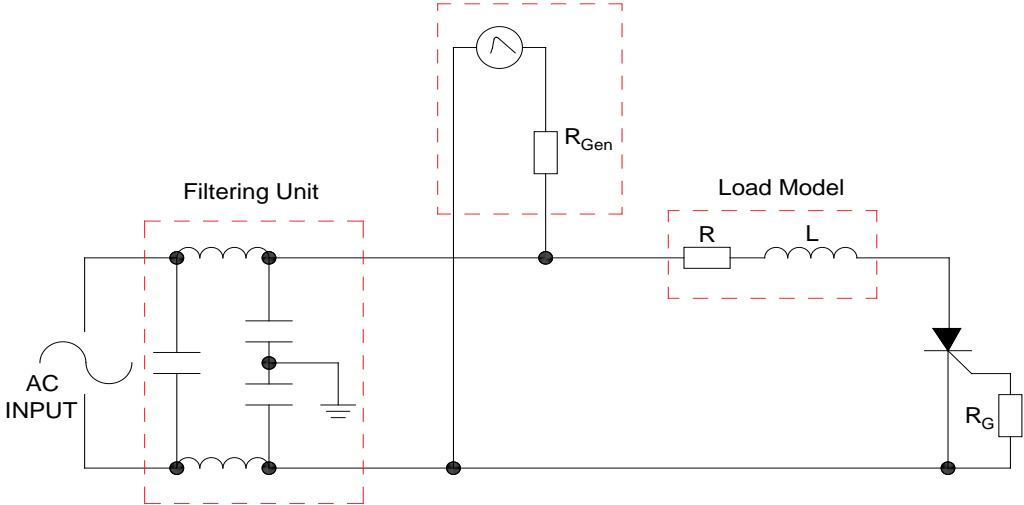

FIG.1:

FIG.7 Test circuit for inductive and resistive loads to IEC-61000-4-5 standards.

IEC61000-4-5 Standards
Surge Generator



Refer to the application note "Assembly Instructions for Thyristors in Through-hole Package" released by JieJie Microelectronics

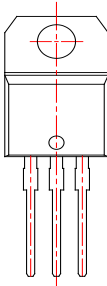

Information furnished in this document is believed to be accurate and reliable.
However, Jiangsu JieJie Microelectronics Co., Ltd.