

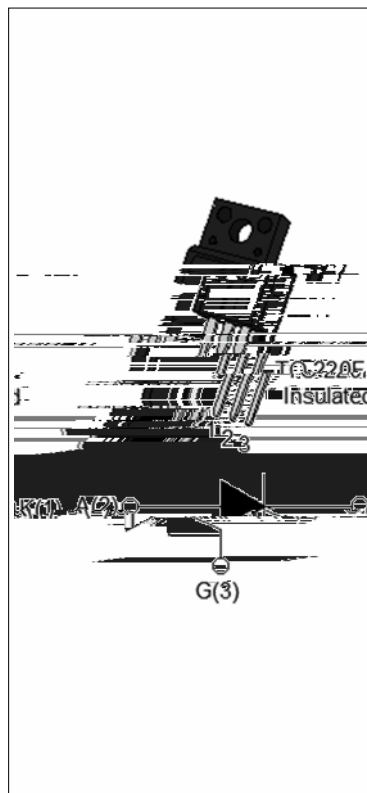

With high ability to withstand the shock loading of large current, JCT812F of silicon controlled rectifiers provides high dV/dt rate with strong resistance to electromagnetic interference. It is especially recommended for use on solid state relay, motorcycle, power charger, T-tools etc. From all three terminals to external heatsink, JCT812F provides a rated insulation voltage of 2000 V_{RMS} , complying with UL standards (File ref: E252906). Package TO-220F is RoHS compliant.



Symbol	Value	Unit
$I_{T(RMS)}$	12	A
V_{DRM}/V_{RRM}	800	V
I_{GT}	15	mA

Parameter	Symbol	Value	Unit
Storage junction temperature range	T_{stg}	-40-150	
Operating junction temperature range	T_j	-40-125	
Repetitive peak off-state voltage ($T_j=25^\circ C$)	V_{DRM}	800	V
Repetitive peak reverse voltage ($T_j=25^\circ C$)	V_{RRM}	800	V
Average on-state current ($T_c = 86^\circ C$)	$I_{T(AV)}$	7.6	A
RMS on-state current ($T_c = 86^\circ C$)	$I_{T(RMS)}$	12	A
Non repetitive surge peak on-state current ($t_p=10ms, T_j=25^\circ C$)	I_{TSM}	140	A
Non repetitive surge peak on-state current ($t_p=8.3ms, T_j=25^\circ C$)		154	
I^2t value for fusing ($t_p=10ms, T_j=25^\circ C$)	I^2t	98	A^2s
Critical rate of rise of on-state current ($I_G=2 \times I_{GT}, f=100Hz, T_j=125^\circ C$)	di/dt	150	$A/\mu s$

Peak gate current ($t_p=20\mu s$, $T_j=125$)	I_{GM}	4	A
Average gate power dissipation ($T_j=125$)	$P_{G(AV)}$	1	W
Peak gate power	P_{GM}	10	W
Peak pulse voltage ($T_j=25$; non-repetitive, off-state; FIG.7)	V_{pp}	0.5	kV

($T_j=25$ unless otherwise specified)

Symbol	Test Condition	Value			Unit
		MIN.	TYP.	MAX.	
I_{GT}	$V_D=12V$ $R_L=33$	-	-	15	mA
V_{GT}		-	-	1	V
V_{GD}	$V_D=V_{DRM}$ $T_j=125$ $R_L=3.3k$	0.2	-	-	V
I_L	$I_G=1.2I_{GT}$	-	-	60	mA
I_H	$I_T=500mA$	-	-	50	mA
dV/dt	$V_D=540V$ Gate Open $T_j=125$	500	-	-	V/ μs
t_{on}	$I_G=20mA$ $I_A=200mA$ $I_R=20mA$ $T_j=25$	-	5	-	μs

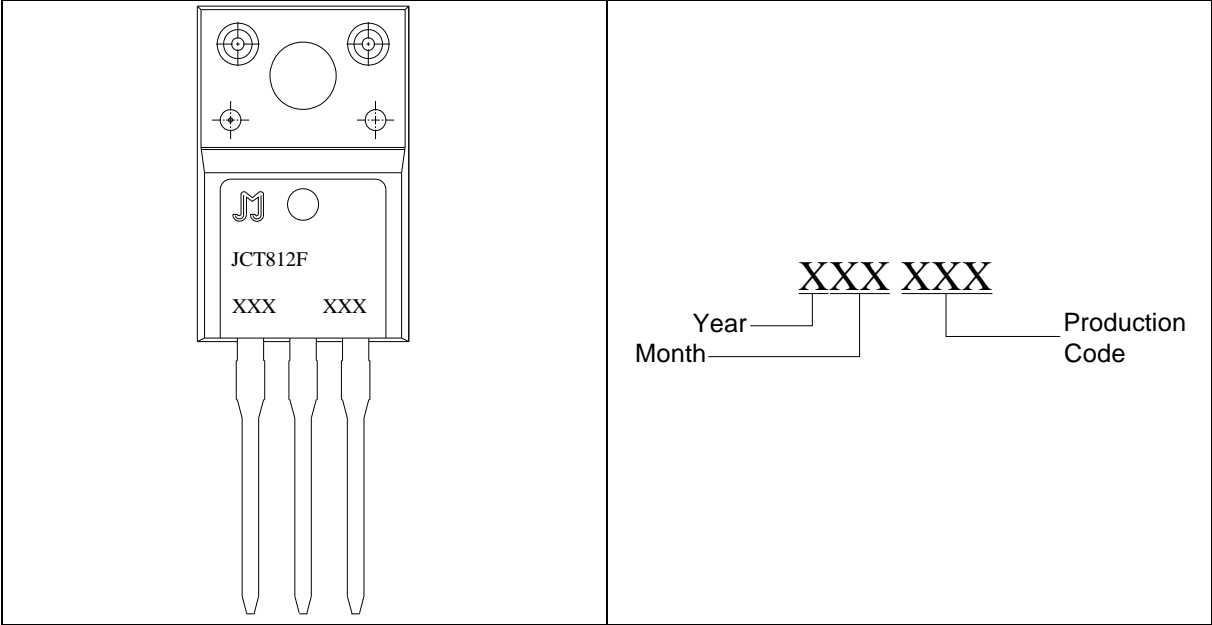
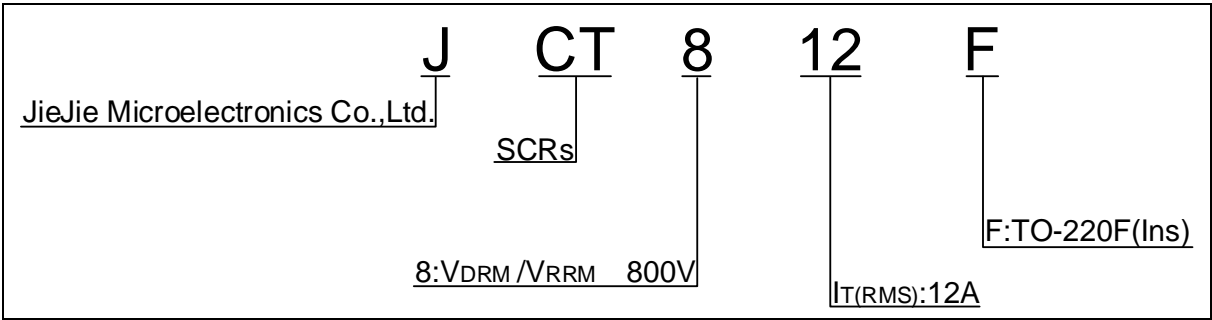
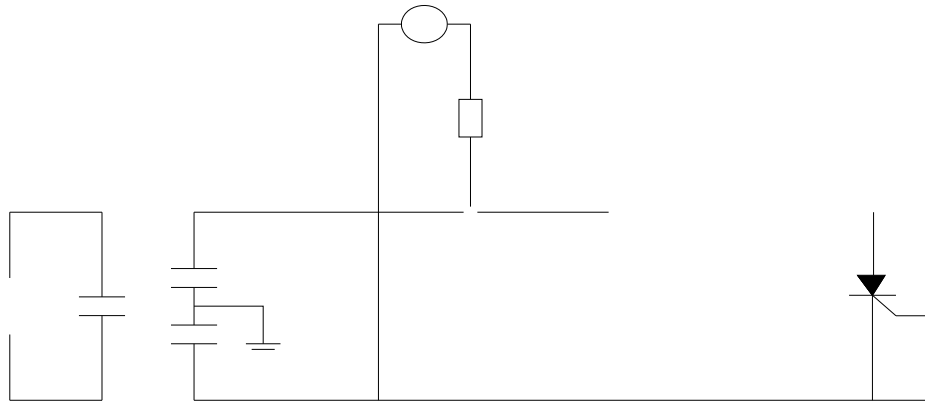
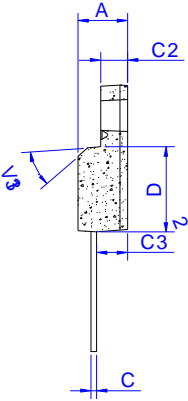
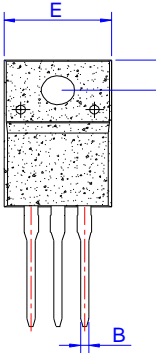
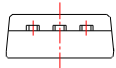

FIG.1: Maximum power dissipation versus
M

FIG.7 Test circuit for inductive and resistive loads to IEC-61000-4-5 standards. -





A

M

Information furnished in this document is believed to be accurate and reliable. However, Jiangsu JieJie Microelectronics Co., Ltd. assumes no responsibility for the consequences of use without consideration for such information nor use beyond it. Information mentioned in this document is subject to change without notice, apart from that when an agreement is signed, Jiangsu JieJie complies with the agreement. Products and information provided in this document have no infringement of patents. Jiangsu JieJie assumes no responsibility for any infringement of other rights of third parties which may result from the use of such products and information. This document supersedes and replaces all information previously supplied.

 is a registered trademark of Jiangsu JieJie Microelectronics Co., Ltd. Copyright © 2025 Jiangsu JieJie Microelectronics Co., Ltd. All rights reserved.