



**Electrical Characteristics** ( $T_J = 25^\circ\text{C}$  unless otherwise specified)

Symbol	Conditions	Min.	Typ.	Max.	Unit
<b>Off Characteristics</b>					
$V_{(BR)DSS}$		30	-	-	V
$I_{DSS}$		-	-	1.0	$\mu\text{A}$
$I_{GSS}$		-	-	$\pm 100$	nA
<b>On Characteristics</b>					
$V_{GS(th)}$		1.2	1.7	2.2	V
		-	15.5	20.2	$\text{m}\Omega$
		-	22.1	28.7	$\text{m}\Omega$
<b>Capacitance and Charge</b>					
$C_{iss}$		-	485	-	pF
$C_{oss}$		-	69	-	pF
$C_{rss}$		-	53	-	pF
$Q_g$		-	10	-	nC
$Q_{gs}$		-	2	-	nC
$Q_{gd}$		-	2	-	nC
<b>Timing</b>					
$t_{d(on)}$		-	4.2	-	ns
$t_r$		-	11	-	ns
$t_{d(off)}$		-	14	-	ns
$t_f$		-	2	-	ns
<b>Static Characteristics</b>					
$I_S$		-	-	9	A



## Typical Performance Characteristics

Figure 1: Output Characteristics

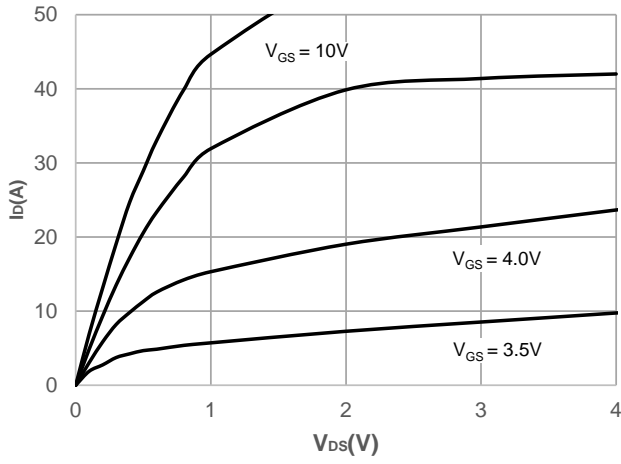

FigFTpFicali ThFist

ics

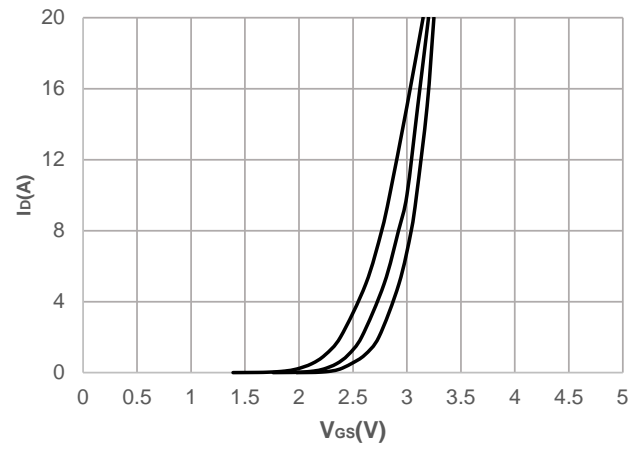



## Typical Performance Characteristics

Figure 7: Normalized Breakdown voltage vs. Junction Temperature

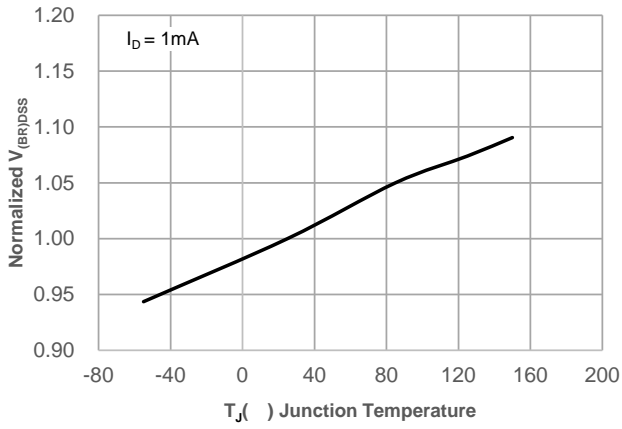

Figure 8: Normalized on Resistance vs. Junction Temperature

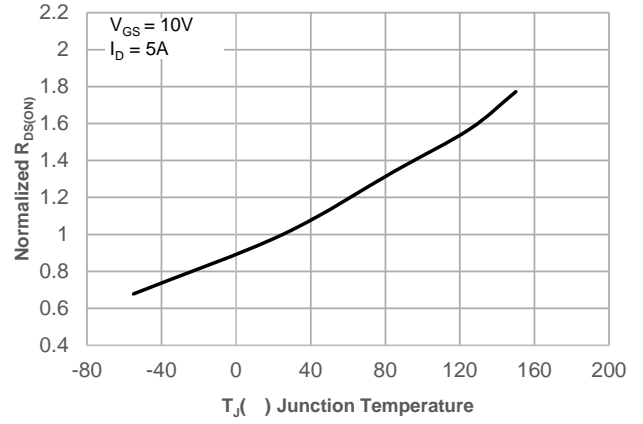
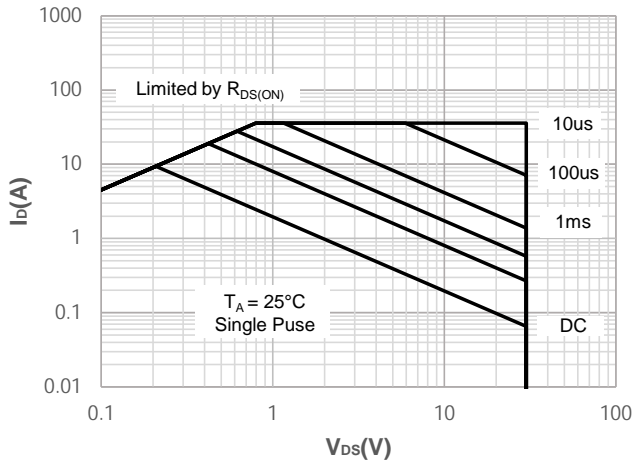

Figure 9: Maximum Safe Operating Area



## Test Circuit

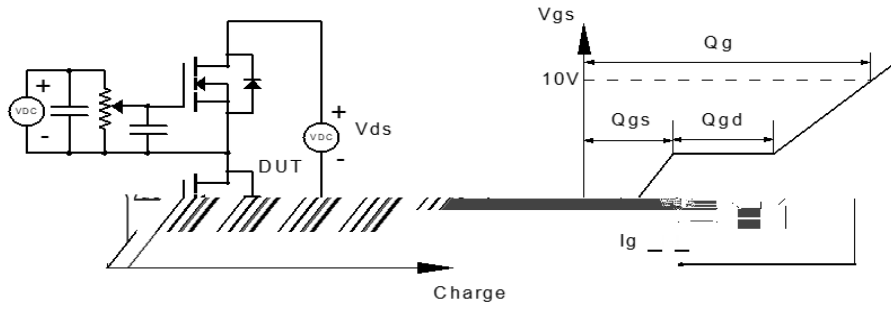

Figure 1: Gate Charge Test Circuit & Waveform

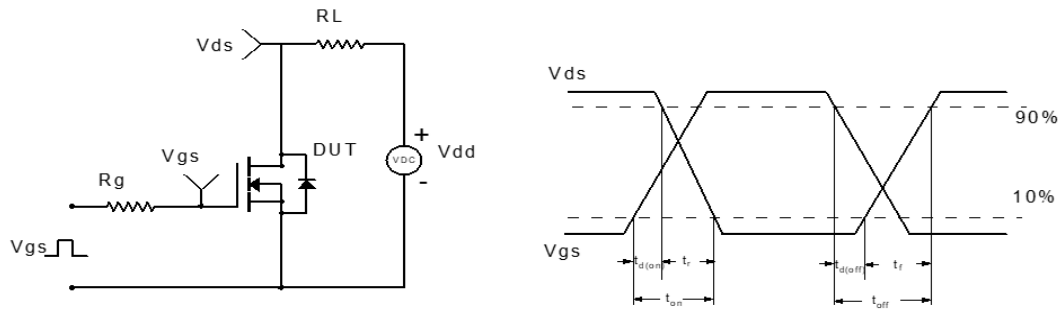

Figure 2: Resistive Switching Test Circuit & Waveform

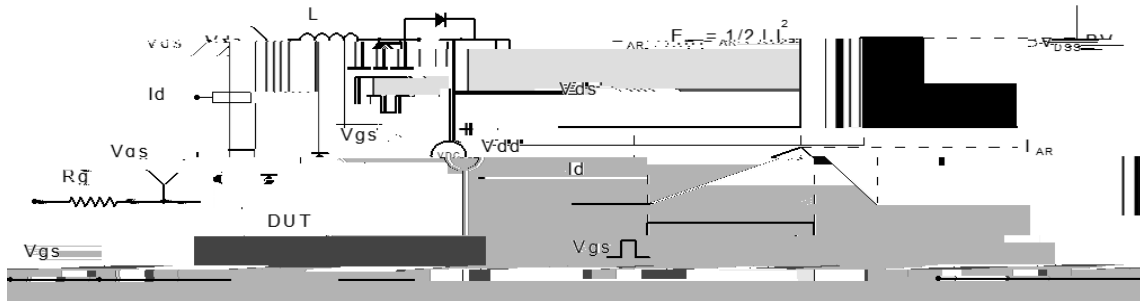

Figure 3: Unclamped Inductive Switching Test Circuit & Waveform

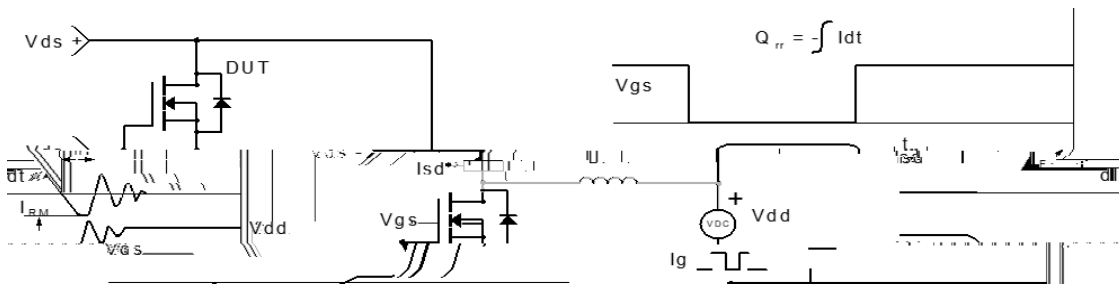

Figure 4: Diode Recovery Test Circuit & Waveform



## Package Mechanical Data(SOP-8)

Information furnished in this document is believed to be accurate and reliable.  
However, Jiangsu